



DESCRIPTION

S67-1575-168: Dual-element Iridium and GPS L1/L2 antenna is designed for military applications with low voltage requirements such as UAV's and DAGR/MAGR receivers. The GPS port features a 26.5 dB LNA with special filtering and an internal voltage regulator which accepts 3.3 to 5 volts. DC-grounded.

The S67-1575-168 is approved as Iridium Compatible Equipment (ICE).

NSN: 5985-01-564-3737

FEDERAL & MILITARY SPECS: DO-160C, TSO-C129a, MIL-DTL-5541, MIL-E-5400, MIL-STD-810.

SPECIFICATIONS	FOR REFERENCE ONLY
MODEL	S67-1575-168
ELECTRICAL	
Frequency	J1 : L1 1565–1585 MHz, L2 1217–1237 MHz J2: 1610–1626 MHz
VSWR	≤ 2.0:1
Polarization	RHCP
Impedance	50 Ohms Nominal
Power Handling	J1: 1 Watt J2: 60 Watts
Gain	-1.0 dBic 0° ≤ θ ≤ 75° -2.5 dBic 75° < θ ≤ 80° -4.5 dBic 80° < θ ≤ 85° -7.5 dBic θ = 90° @ Horizon
Gain (Preamplifier)	26.5 ±3 dB
Voltage	3.3 TO +5 VDC @ 65 mA max
Lightning Protection	DC Grounded
MECHANICAL	
Weight	16 oz.
Height	.92 in.
Length	7.86 in.
Width	3.00 in.
Material	6061-T6 aluminum
Finish	Skydrol-resistant enamel
Connectors	Type "TNC" Female (2)
ENVIRONMENTAL	
Temperature	-54°C (-65°F) TO +110°C (+230°F)
Vibration	10 Gs
Altitude	-1500 to 70,000 ft

PERFORMANCE

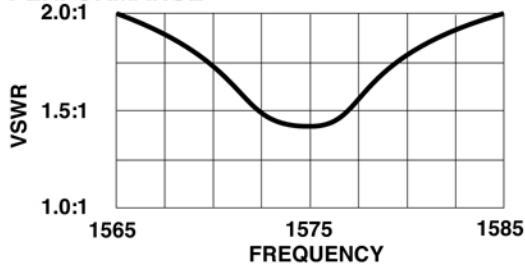

RADIATION PATTERN

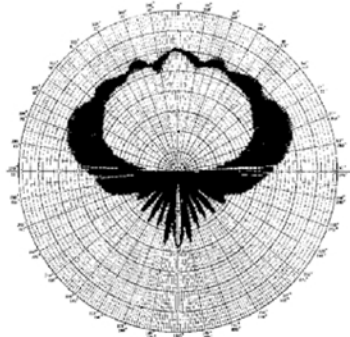

OUTLINE DRAWING

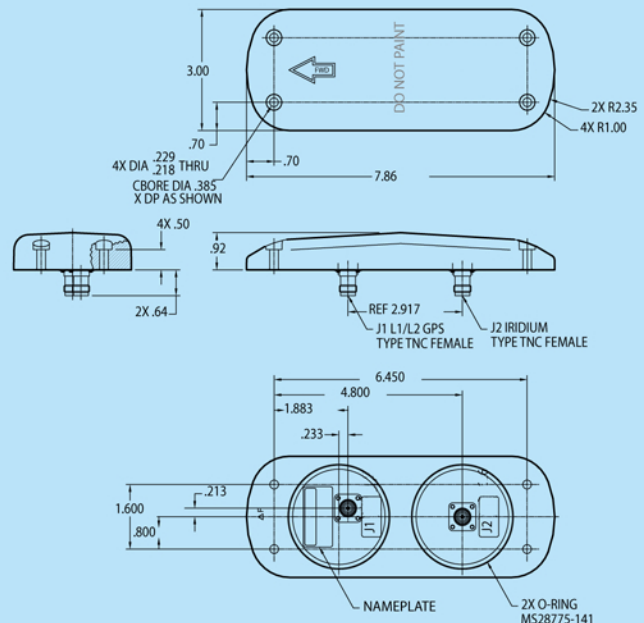

S67-1575-168

ISO 9001:2000 and EN/JISQ/AS9100:2004 Registered

