

UHF/L-Band S65-1226-8

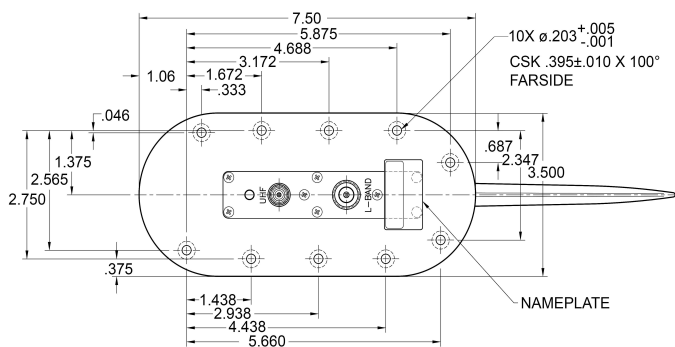
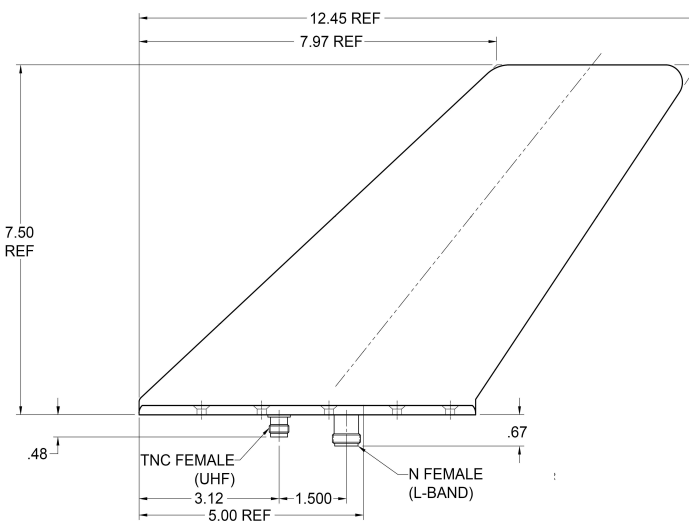

Please Note: For REFERENCE ONLY
Contact Sensor Systems for latest drawing

Description

This small dual-frequency blade antenna incorporates a special filter that provides 40 dB isolation. The antenna is rugged in design with low drag characteristics that make it suitable for high-speed military aircraft. Its 7.5 inch height also makes it ideal for rotor wing aircraft and UAV's where mounting space may be a concern.

The **S65-1226-8**'s construction is all metal and DC grounded for superior lightning protection. The antenna is hermetically sealed for a long service life. The antenna base plate conforms to military bolt hole patterns.

Federal & Military Certifications:

MIL-6271A, MIL-A-7772B, MIL-A-9094C, MIL-E-5272C, MIL-E-5400H and MIL-STD-810.

Specifications

Electrical

Frequency	UHF: 225-400 MHz L-Band: 960-1220 MHz
VSWR	UHF (225-400 MHz): ≤2.3:1 UHF (400-450 MHz): ≤3.0:1 L-Band (960-1220 MHz): ≤2.3:1 L-Band (1000-1100 MHz): ≤2.0:1
Gain	UHF: +3 dBi L-Band: +3 dBi
Polarization	Vertical
Pattern	1/4 Wave Monopole
Impedance	50 Ω
Power	UHF: 100 Watts Continuous L-Band: 4000 Watts Peak, 100 Watts Continuous
Isolation	40 dB
Efficiency	90%

Mechanical

Weight	1.9 lbs.
Height	7.50 in.
Length	12.40 in.
Width	3.50 in.
Material	A356-T61 Aluminum Alloy
Finish	Skydrol Resistant Enamel
Connector	TNC Female N Female
Drag	M.85 @ 35,000 ft. = 7.0 lbs.

Environmental

Temperature	-53°C (-65°F) to +93°C (+203°F)
Altitude	70,000 ft.



A HEICO COMPANY

Website: www.sensorantennas.com

Phone: 818-341-5366