

VHF S65-8280-18

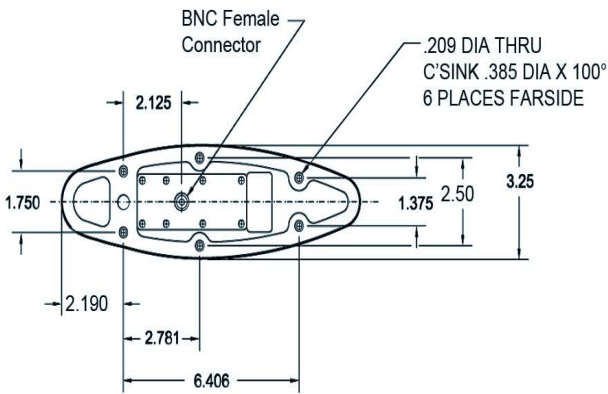
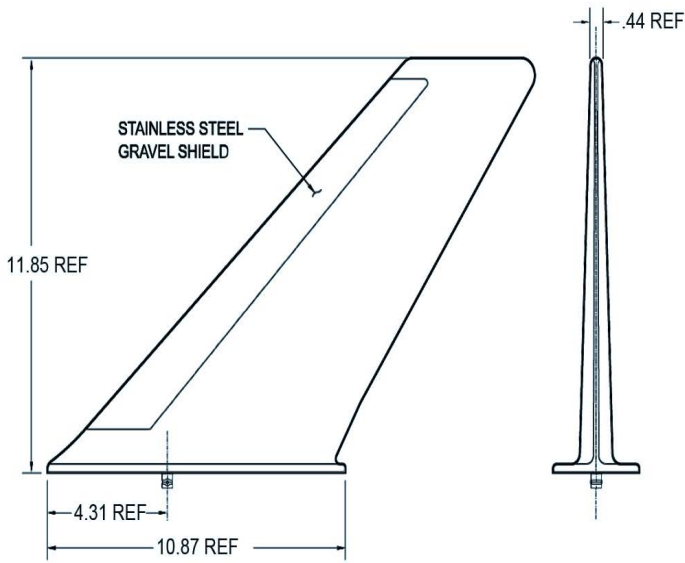

Please Note: For REFERENCE ONLY
Contact Sensor Systems for latest drawing

Description

S65-8280-18: Broadband, all-metal, VHF blade antenna with a frequency range of 116 to 156 MHz. The antenna is DC grounded to eliminate "P" static and provide lightning protection. The antennas features a stainless steel leading edge for gravel protection. The antenna is hermetically sealed.

This antenna is interchangeable with Collins 37R-2, VC10-126, DMC 60 and a variety of other VHF communication antennas.

Federal & Military Certifications: FAA TSO C-37b,C38b, and C169a, DO-160D/G, MIL-A-6271A, MIL-HDBK-5400, MIL-STD-810B/D and SAE ARP5416.

Specifications

Electrical

Frequency	116-156 MHz
VSWR	≤ 2.0:1
Polarization	Vertical
Pattern	Omnidirectional in Azimuth Cosinusoidal in Elevation
Impedance	50 Ω
Power	40 Watts

Mechanical

Weight	3.3 lbs.
Height	11.85 in.
Length	10.87 in.
Width	3.250 in.
Material	A-356 T6 Aluminum Alloy
Finish	Skydrol Resistant Enamel
Connector	BNC Female
Drag	1.0 lbs. Mach .85 @ 35,000 ft.

Environmental

Temperature	-54°C (-65°F) to +71°C (+160°F)
Altitude	55,000 ft.



A HEICO COMPANY

Website: www.sensorantennas.com

Phone: 818-341-5366