

# VHF S65-8280-68



## Description

**S65-8280-68:** All metal broadband antenna with DC grounding to provide lightning protection. The all metal design eliminates "P" static and is hermetically sealed. The antenna is ideal for commercial and business aircraft.

This VHF antenna is interchangeable with the Collins 37R-2, VC10-126, DMC 60 and other various VHF communications.

**Federal & Military Certifications:** FAA TSO-C37b and C38b, MIL-A-6271A, MIL-A-7772B (ASG), MIL-A-9094C, MIL-E-5272H and MIL-E-5400H.

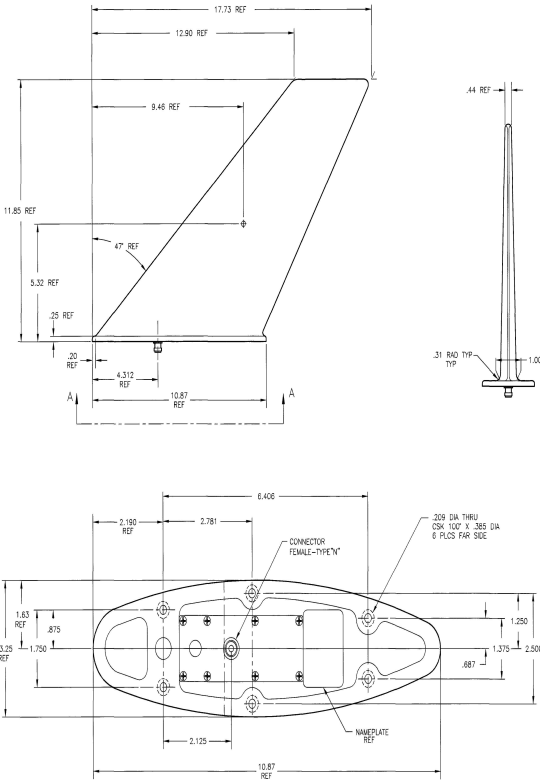

## Specifications

### Electrical

Frequency	116-156 MHz
VSWR	≤ 2.0:1
Polarization	Vertical
Patterns	Omni/AZ; Cos/EL
Impedance	50 Ω
Power	250 Watts

### Mechanical

Weight	3.3 lbs.
Height	11.85 in.
Length	10.87 in.
Width	3.25 in.
Material	A356-T6 Aluminum Alloy Casting
Finish	Skydrol Resistant Enamel
Connector	N Female
Drag	1.5 lbs. Mach .85 @ 35,000 ft.

### Environmental

Temperature	-55°C (-67°F) to +85°C (+185°F)
Altitude	55,000 ft.

Please Note: For REFERENCE ONLY  
Contact Sensor Systems for latest drawing



A HEICO COMPANY

Website: [www.sensorantennas.com](http://www.sensorantennas.com)

Phone: 818-341-5366