

GPS L1 Antenna S67-1575-52

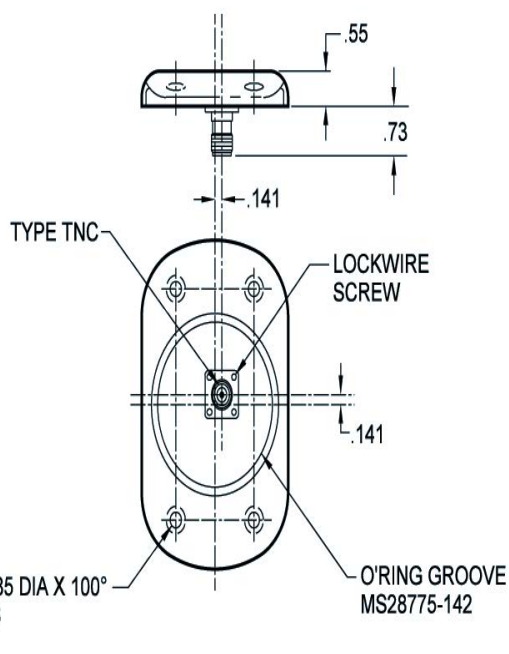

Please Note: For REFERENCE ONLY
Contact Sensor Systems for latest drawing

Description

S67-1575-52: GPS L1 antenna in an ARINC 743A configuration. Features a 26 dB amplifier and special filtering for airline applications. DC bias is provided through the coax connector. Internal voltage regulator accepts +4 to +24 VDC. Low-profile, advanced radome design and material displays enhanced protection against rain, ice and lightning strikes. DC grounded and hermetically sealed.

FEDERAL & MILITARY SPECS: FAA TSO-C129 & TSO-C115a, ARINC 743, DO-160C, MIL-E-5400, MIL-C-5541.

Specifications

Electrical

Frequency	1572.42 MHz
VSWR	2.0:1
Polarization	RCHP
Gain Coverage (min)	-1.0 dBic $0^\circ \leq \theta \leq 75^\circ$
	-2.5 dBic $75^\circ \leq \theta \leq 80^\circ$
	-4.5 dBic $80^\circ \leq \theta \leq 85^\circ$
	-7.5 dBic $\theta = 90^\circ$ @ Horizon
Gain (Preamp)	26.0 dB
Impedance	50 Ω
Power Handling	100 mW
Voltage	+4 to +24 VDC
Axial Ratio	≤ 3 dBic @ Zenith

Mechanical

Weight	6 oz.
Height	.55 in.
Width	3.0 in.
Width	4.70 in.
Material	6061-T6 Aluminum Alloy / Thermoset Plastic
Finish	Skydrol Resistant Polyurethane Enamel
Connector	TNC Female

Environmental

Temperature	-55°C (-67°F) to +85°C (+185°F)
Altitude	55,000 ft.

Accessories

Conductive Gasket	S67-200229
Mounting Screws	MS24693C275



A HEICO COMPANY

Website: www.sensorantennas.com

Phone: 818-341-5366