

VHF S65-8280-42

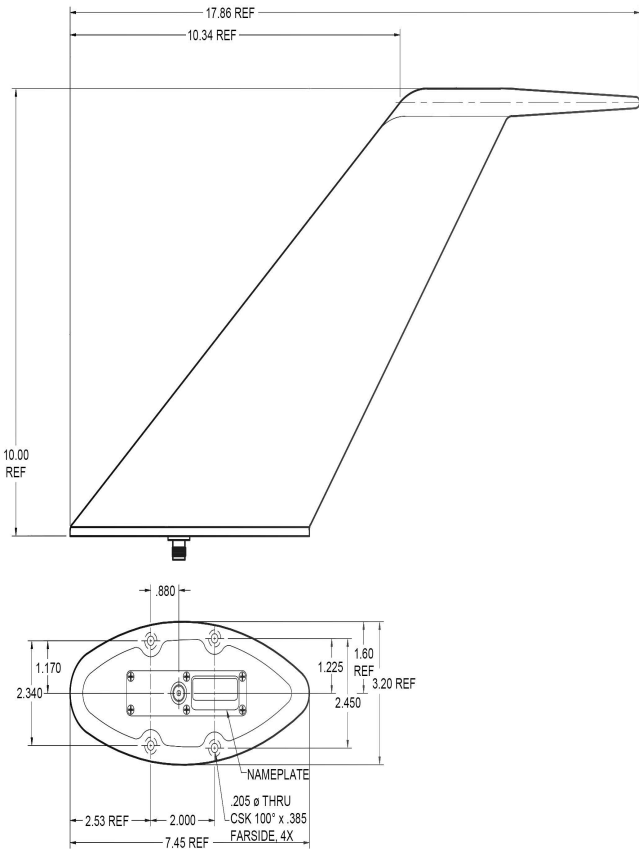

Please Note: For REFERENCE ONLY
Contact Sensor Systems for latest drawing

Description

S65-8280-42: All-metal, light weight and low drag VHF communication antenna with a rugged exterior. The antenna is DC grounded to provide lightning protection and eliminate "P" static. It is hermetically sealed and features a four hole bolt pattern.

The antenna is ideal for general aviation and corporate aircraft.

The antenna is interchangeable with Chelton 21-38, Dayton Granger VC10-126 and Chelton 12-1 through 12-7 series

Federal & Military Certifications: FAA TSO C-37b, and C38b, DO-160, MIL-A-6271, MIL-A-7772, MIL-E-5400, MIL-STD-464 and MIL-STD-810.

Specifications

Electrical

Frequency	118-152 MHz
VSWR	≤ 2.5:1
Polarization	Vertical
Patterns	1/4 Wave Monopole
Impedance	50 Ω
Power	40 Watts

Mechanical

Weight	2.0 lb.
Height	10.00 in.
Length	7.45 in.
Width	3.20 in.
Material	A-356 Aluminum Alloy
Finish	Gloss White
Connector	TNC Female

Environmental

Temperature	-54°C (-65°F) to +85°C (+185°F)
Altitude	60,000 ft.



A HEICO COMPANY

Website: www.sensorantennas.com

Phone: 818-341-5366