

X-Band Radar Transponder **S65-1200**



Description

This is an all-metal antenna designed for the X-band transponder use of high gain patterns on the horizon. The antenna features a 4-hole base plate design that provides a common installation for commercial airline application..

The **S65-1200** antenna's coax-to-waveguide connector offers high power capability. The antenna works with the AWACS transponder and is ideal for military applications for in-flight refueling and other tactical operations.

Specifications

Electrical

Frequency	8800-9500 MHz
VSWR (50 Ω Ref.)	8800-9500 MHz: ≤1.5:1 9150-9400 MHz: ≤2.5:1
Polarization	Horizontal
Pattern	Approx. ±10° Vertical -Essentially Omnidirectional in Azimuth
Power	400 Watts Peak, Duty Cycle .002 to 40,000 ft.
Isolation	VHF: 132-174 MHz ≥20 dB UHF: 225-400 MHz ≥20 dB
Efficiency	85%
Directivity	7 dB Above Isotropic Reference - Min. 80%

Mechanical

Weight	2.0 lbs. Max.
Height	8.9 in.
Material	A612-F Aluminum Alloy
Finish	Polyurethane Gloss
Connector	TNC Female
Drag	Mach 0.85 @ 35,000 ft. = 1.5 lbs.

Environmental

Temperature	-55°C (-67°F) to +71°C (+160°F)
Altitude	55,000 ft.

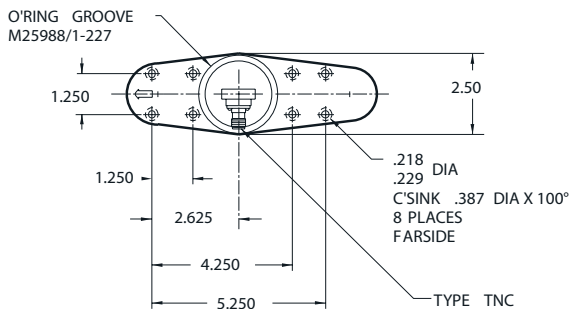
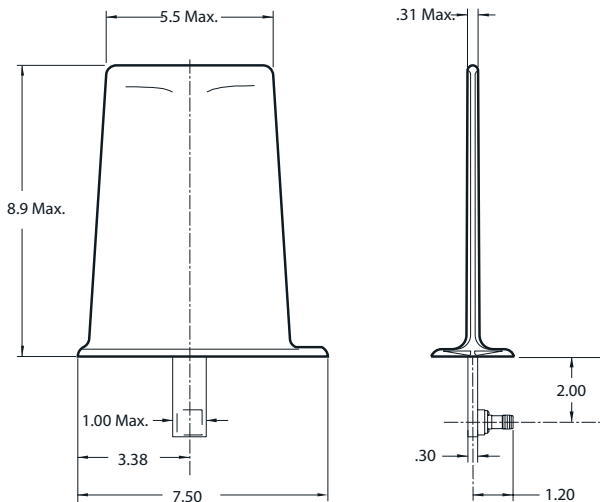

Please Note: For REFERENCE ONLY
Contact Sensor Systems for latest drawing



A HEICO COMPANY

Website: www.sensorantennas.com

Phone: 818-341-5366