

# GPS WAAS Antenna S67-1575-135



## Description

**S67-1575-135:** WAAS LPV GPS L1 antenna with 33dB gain low-noise amplifier in an ARINC 743A configuration. Meets HIRF/EMI and TSO C190 requirements for all critical level MMR installations. The amplifier section incorporates special filtering providing significant out-of-band rejection while still maintaining full bandwidth. The internal voltage regulator accepts +4 to +24 volts DC.

DC bias is provided through the coaxial connector.

**FEDERAL & MILITARY SPECS:** FAA TSO C190, DO-160C/E, DO-301, MIL-STD-810, MIL-HDBK-5400, ARINC 743A.

## Specifications

### Electrical

Frequency	1575.42 ± 10.23 MHz
VSWR	≤ 1.5:1
Polarization	RCHP
Axial Ratio	≤ 3.0 dB @ Zenith
Gain Coverage (min)	-1.0 dBic 0° ≤ Θ ≤ 75°
	-2.5 dBic 75° ≤ Θ ≤ 80°
	-4.5 dBic 80° ≤ Θ ≤ 85°
	-7.5 dBic Θ = 90° @ Horizon
Impedance	50 Ω
GT ± 2 MHz	-31.6 dB/K @ 5° ABOVE THE HORIZON
Gain (Preamp)	33 ± 3 dB
Differential Group Delay	<25nS
Power Handling	1W (+30dBm for 5 min.)
Supply Voltage	+4 to +24 VDC @ 60 mA MAX

### Mechanical

Weight	10 oz.
Height	.73 in.
Width	3.0 in.
Length	4.70 in.
Finish	Skydrol Resistant Polyurethane Enamel
Material	6061-T6 Aluminum Alloy / Thermoset Plastic
Connector	TNC Female

### Environmental

Temperature	-55 ° C (-67°F) to 70 ° C (+158°F)
Altitude	-100 to 55,000 ft.

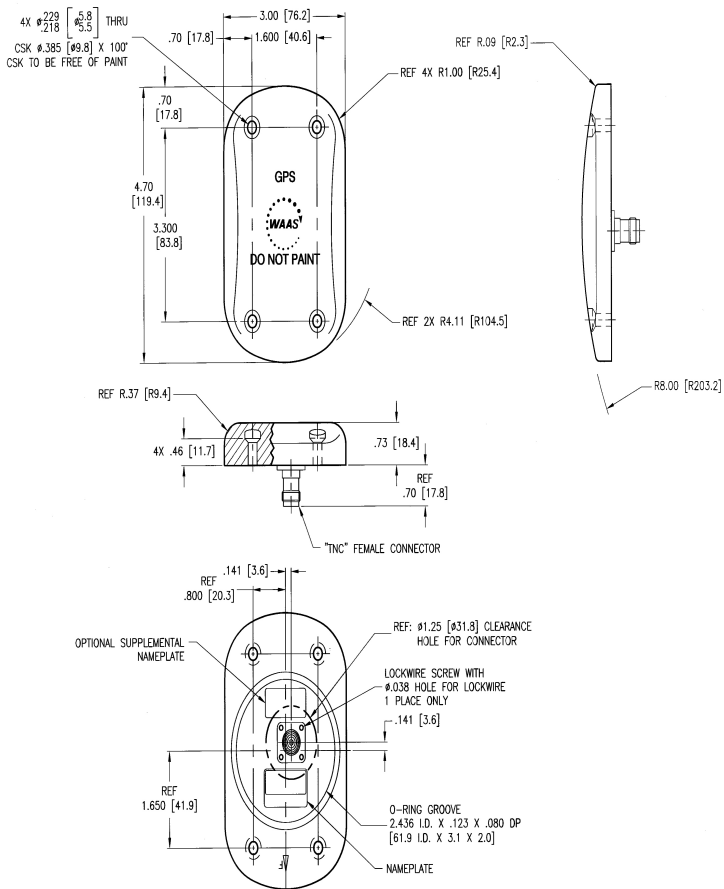

Please Note: For REFERENCE ONLY  
Contact Sensor Systems for latest drawing



A HEICO COMPANY

Website: [www.sensorantennas.com](http://www.sensorantennas.com)

Phone: 818-341-5366